

Lighting Solutions





We know that all of us have been affected by Hurricane Irma.

Lighting Dynamics is open and ready to help.

We here at Lighting Dynamics are committed to South Florida. As part of this commitment we have created a list of products that we have partnered with Eaton to make available to help re-build our lives after the storm. From LED to Solar Lighting, Lighting Dynamics can help re-light S. Florida after Hurricane Irma.

Solutions

- SOLAR:
 - MST800LW (SHOWN ABOVE)
 - MST1301LW
 - MSS1301LW
 - MSLED180 W
- SITE LIGHTING: LUMARK PREVAIL LED
- FLOOD LIGHTING: LUMARK NIGHT FALCON LED
- CANOPY LIGHTING: LUMARK
- WALL PACKS: REVOLVE



ALL-PRO: DIVERGE OFF GRID LIGHTING SYSTEM (WPS2040M)

The Diverge™ off-grid lighting system is a portable solution, utilizing rechargeable lithium-ion battery technology and multiple charging options for a wide range of applications. Delivering an impressive 2400 lumens at full charge, the fixture offers an integrated dimming control, 360 degree motion sensor, polycrystalline solar panel with 20' cord and two USB interfaces for charging purposes. Suitable for storage, marine, remote location and area lighting where 120V wiring is not available.

Recommended



ALL-PRO™











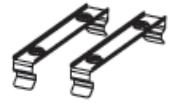

Instruction Manual / Manuel d'instructions / Instrucciones

Questions? / Des questions? / ¿Preguntas? 1-800-334-6871 ConsumerProducts@eaton.com

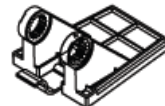

WPS2040M

PACKAGING CONTENTS / CONTENIDO DEL PAQUETE

- | | | | | |
|---|--|---|---|--|
| <p>A. Light fixture
Luminaire
Luminaria</p> | <p>B. Solar panel with 3ft. cord
Panneau solaire avec
cordon de 0,9 m (3 pi)
Panel solar con cable de
3 pies (0,91 m)</p> | <p>C. (2) Mounting brackets
(2) Supports de montage
(2) Soportes de montaje</p> | <p>D. Mounting base
Base de montage
Base de montaje</p> | <p>E. Mounting stand
Socle de montage
Plataforma de
montaje</p> |
|  |  |  |  |  |
| <p>F. Mounting pin
Goupille de montage
Clavija de montaje</p> | <p>G. Mounting pin cap
Capuchon de goupille
de montage
Tapa para clavija de
montaje</p> | <p>H. Mounting friction gasket
Joint de frottement de montage
Arandela de fricción de montaje</p> | <p>I. Mounting plate
Plaque de montage
Placa de montaje</p> | <p>J. (8) Mounting screws
(8) vis de montage
(8) Tornillos de montaje</p> |
|  |  |  |  |  |
| <p>K. (4) Drywall anchors
(4) dispositifs d'ancrage
pour cloison sèche
(4) Anclajes para panel de yeso</p> | <p>L. 6ft. USB Cable
De 1,8 m (6 pi) Câble USB
Cable USB de 6 pies (1,8 m)</p> | <p>M. 17ft. Solar panel extension cord
De 5 m (17 pi) Rallonge électrique pour le panneau d'alimentation
Cable de extensión para paneles solares de 17 pies (5,18 m)</p> | | |
|  |  |  | | |

ALL-PRO: MSS1301LW

Solar powered LED twin head motion activated light with 130° of motion coverage. Compact design can be used in a wide range of applications.

Features

- Motion sensor detects motion 130° up to 25 ft
- Produces 240 lumens
- Equivalent light output of a 20-watt incandescent fixture
- 3" x 5" Solar Panel with 16 ft. cord for flexible mounting options
- Easy installation with attached mounting clip



ALL-PRO™

Instruction Manual / Manuel d'instructions / Instrucciones

Questions? / Des questions? / ¿Preguntas? 1-800-334-6871 ConsumerProducts@eaton.com

PACKAGING CONTENTS / CONTENIDO DEL PAQUETE

A. Light fixture with 12 in. lead wire connector
Accesorio para la luz con conector de cable de 12 pulg
Luminaire avec fil de sortie et capuchon de connexion
de 30,5 cm (12 po)



B. Solar panel (150x110 mm)
with 15 ft. cord
Panel solar (150x110 mm)
con cable de 15 pies
Panneau solaire (150x110 mm)
avec cordon de 4,6 m (15 pi)



C. (2) Fixture mounting screws
(2) Tornillos de montaje del accesorio
(2) Vis de montage du luminaire



D. (4) Solar panel mounting screws
(4) Tornillos de montaje del panel solar
(4) Vis de montage de panneau solaire



E. Snap-in mounting bracket
Soporte de montaje de sujeción
a presión
Support de montage encastrable



MSS1301LW

ALL-PRO: MST1301LW

Solar powered LED twin head motion activated light with 130° of motion coverage. Compact design can be used in a wide range of applications.

Features

- Motion sensor detects motion 130° up to 25 ft
- Produces 320 lumens
- Equivalent light output of a 30-watt incandescent fixture
- 3" x 5" Solar Panel with 16 ft. cord for flexible mounting options
- Easy installation with attached mounting clip



ALL-PRO™

Instruction Manual / Manuel d'instructions / Instrucciones

Questions? / Des questions? / ¿Preguntas? 1-800-334-6871 ConsumerProducts@eaton.com

PACKAGING CONTENTS / CONTENIDO DEL PAQUETE

A. Light fixture with 12 in. lead wire connector
Accesorio para la luz con conector de cable de 12 pulg
Luminaire avec fil de sortie et capuchon de connexion
de 30,5 cm (12 po)

B. Solar panel (150x110 mm)
with 15 ft. cord
Panel solar (150x110 mm)
con cable de 15 pies
Panneau solaire (150x110 mm)
avec cordon de 4,6 m (15 pi)

C. (2) Fixture mounting screws
(2) Tornillos de montaje del accesorio
(2) Vis de montage du luminaire

D. (4) Solar panel mounting screws
(4) Tornillos de montaje del panel solar
(4) Vis de montage de panneau solaire

E. Snap-in mounting bracket
Soporte de montaje de sujeción
a presión
Support de montage encastrable



MST1301LW

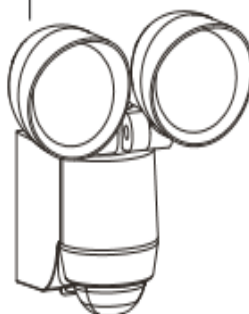

(Single head position)
(Posición de cabezal simple)
(Position à tête regroupée)



(Twin head position)
(Posición de cabezal doble)
(Position à tête séparée)

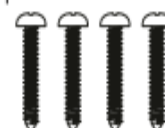

ALL-PRO: MST800LW

Solar Powered. 180° Motion sensor, solar powered high output LED motion activated light. Unique design can be used as a twin head or single head depending on application.

Features

- Motion sensor detects motion 180° up to 70 ft.
- Produces over 1000 lumens
- Equivalent light output of a 90-watt incandescent fixture
- 6" x 8" Solar Panel with 16 ft. cord for flexible mounting options
- Easy installation with attached mounting clip
- LED indicator light flashes when unit needs to recharge



ALL-PRO™

Instruction Manual / Manuel d'instructions / Instrucciones

Questions? / Des questions? / ¿Preguntas? 1-800-334-6871 ConsumerProducts@eaton.com



MST800LW

PACKAGING CONTENTS / CONTENIDO DEL PAQUETE

A. Light fixture with 12 in. lead wire connector
 Accesorio para la luz con conector de cable de 12 pulg
 Luminaire avec fil de sortie et capuchon de connexion
 de 30,5 cm (12 po)



(Single head position)
 (Posición de cabezal simple)
 (Position à tête regroupée)

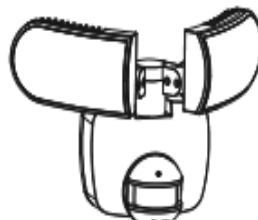

(Twin head position)
 (Posición de cabezal doble)
 (Position à tête séparée)

B. Solar panel with 15 ft. cord
 Panel solar con cable de 15 pies
 Panneau solaire avec cordon
 de 4,6 m (15 pi)



D. (4) Solar panel mounting screws
 (4) Tornillos de montaje
 del panel solar
 (4) Vis de montage de panneau
 solaire

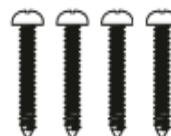

C. (2) Fixture mounting screws
 (2) Tornillos de montaje del accesorio
 (2) Vis de montage du luminaire



E. Snap-in mounting bracket
 Soporte de montaje de sujeción
 a presión
 Support de montage encastrable



ALL-PRO: MSLED180 SERIES

Solar Powered. 180° Motion sensor, solar powered high output LED motion activated light. Unique design can be used as a twin head or single head depending on application.

Features

- Motion sensor detects motion 180° up to 70 ft.
- Durable, weather-resistant plastic construction
- Easy wall-mounting with no wiring necessary
- Adjustable time settings
- 6" x 8" solar panel for maximum charging power with 16' cord
- LED indicator light flashes when unit needs to recharge



ALL-PRO™

Instruction Manual / Instrucciones

Questions? / ¿Preguntas? 1-800-334-6871 ConsumerProducts@eaton.com



MSLED180 (Black)
MSLED180W (White)

PACKAGING CONTENTS / CONTENIDO DEL PAQUETE

A. Light fixture with 12 in. lead wire connector
Accesorio para la luz con conector de cable de 12 pulg

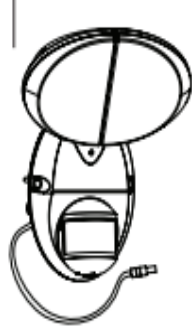

(Single head position)
(Posición de cabezal simple)

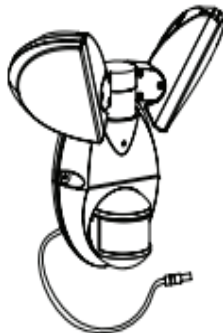

(Twin head position)
(Posición de cabezal doble)

B. Solar panel with 15 ft. cord
Panel solar con cable de 15 pies

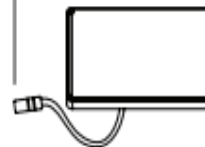

D. (4) Solar panel mounting screws
(4) Tornillos de montaje del panel solar



C. (2) Fixture mounting screws
(2) Tornillos de montaje del accesorio



ALL-PRO: MSLED300

The MSLED300 solar powered LED solution provides light anywhere you need it, without the need for wiring or expensive batteries. Delivering 300 lumens at a full charge, this fixture can be used in a multitude of outdoor applications and can be installed in seconds. Designed for convenience, the snap-in mounting tab allows for portable use, while the integrated 120 degree motion

Features

- No wiring needed; integrated solar panel for hassle-free installation
- Integrated battery pack provides 60 min. run time on a full charge
- 120 degree motion sensor turns light on when motion is detected



ALL-PRO™

Instruction Manual / Manuel d'instructions / Instrucciones

Questions? / Des questions? / ¿Preguntas? 1-800-334-6871 ConsumerProducts@eaton.com



MSLED300W
(White/Blanco/Blanc)

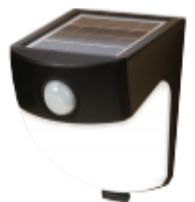

MSLED300
(Black/Noir/Negro)

PACKAGING CONTENTS / CONTENIDO DEL PAQUETE

A. Light fixture
Accesorio
Luminaire



B. Snap-in mounting bracket
Soporte de montaje de sujeción a presión
Support de montage encastrable

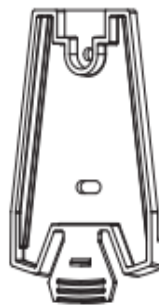

Quick Release Tab
Lengüeta de liberación rápida
Languette à dégagement rapide

C. (2) Fixture mounting screws
(2) Tornillos de montaje del accesorio
(2) Vis de montage du luminaire



Revolve™ LED Motion Activated Floodlight

The patents-pending Revolve™ LED outdoor security product line by All-Pro™ combines advanced LED technology and industry-leading optic design to bring you a low-profile fixture with uncompromising performance. An integral photo control provides nighttime ON, daytime OFF functionality. Refractive optics eliminate the need for bulky reflectors, while allowing you to easily aim the light precisely where you need it by simply rotating the optic. The end result is a sleek, aesthetically appealing LED fixture that remains virtually unnoticeable when not in use.



ALL-PRO™

Revolve™

Instruction Manual / Instrucciones

MOTION ACTIVATED

Questions? / ¿Preguntas? 1-800-334-6871 ConsumerProducts@eaton.com



REV218535M / REV218535MW
REV21850M / REV21850MW

FLOOD



REV235F / REV235FW
REV250F / REV250FW

DUSK TO DAWN



REV235PC / REV235PCW
REV250PC / REV250PCW

(Bronze/Bronce) and (White/Blanco)

PACKAGING CONTENTS / CONTENIDO DEL PAQUETE

A. Light fixture
Accesorio

B. Adjustable Mounting Bracket
Soporte de montaje ajustable

C. (2) #8-32 x 3/4 in. and (2) #10-24 x 3/4 in. junction box screws (use the size that fits your junction box)
(2) Tornillos #8-32 x 3/4 pulg. y (2) tornillos #10-24 x 3/4 pulg. para montaje de la caja de conexiones (utilice el tamaño que mejor se adecue a su caja de conexiones)

D. Adapter Cable
Cable adaptador



E. (2) #10-24 x 1-1/4 in. cover mounting screws (pre-attached)
(2) Tornillos #10-24 x 1-1/4 pulg. de montaje de la cubierta (préfixé)

F. (2) Decorative screw cover caps
(2) Cubiertas tapatornillos decorativas

G. (2) Wire Nuts
(2) Tuercas para alambre

H. Optic Rotator Tool
Herramienta para rotar la óptica

I. #6 x 5/16 in. sheet metal screws
Tornillos de metal para chapas N.º 6 x 5/16 pulg.



ALL-PRO LED Wall Pack Dusk to Dawn

The ALL-PRO™ LED Wall Pack Series incorporates advanced LED technology and optical design to bring you a slim-profile luminaire with uncompromising performance. Multiple control options are available, including integral photo control for dusk-to-dawn operation and flood for switch control. This fixture provides area coverage equivalence up to 100W Metal Halide while achieving substantial energy and maintenance savings. Perfect for illuminating residential, light commercial, apartments and hotel buildings.



ALL-PRO™

Instruction Manual / Manuel d'instructions / Instrucciones

Questions? / Des questions? / ¿Preguntas? 1-800-334-6871 ConsumerProducts@eaton.com



WP1050LPC
WP1850LPC



WP1050L
WP1850L

PACKAGING CONTENTS / CONTENU DE L'EMBALLAGE / CONTENIDO DEL PAQUETE

A. Housing

Boîtier

Alojamiento

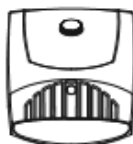

B. Back cover (Preinstalled to housing)

Couvercle arrière (préinstallé sur le boîtier)

Cubierta trasera (preinstalada en el alojamiento)



C. (2) #8-32 x 3/4 in. junction box screws

(2) vis n° 8 de 3/2 x 3/4 po pour boîtier de jonction

(2) tornillos #8-32 x 3/4 pulg. para montaje de la caja de conexiones



LUMARK: NFFLD NIGHT FALCON

The Night Falcon™ LED floodlight luminaire combines high-efficiency optics, superior thermal management and energy efficiency in a cost effective solution. The compact, robust design incorporates a separate driver compartment for maximum heat dissipation resulting in longer fixture and LED life. The Night Falcon luminaire uses precision engineered optics delivering superior uniformity and excellent illumination to the targeted application. Typical applications include area lighting for security, building facade lighting, accent and signage lighting in both commercial and industrial applications. The Night Falcon luminaire is UL/cUL listed for wet locations and is IP66 and 3G vibration rated.



DIMENSIONS

Slipfitter Mount

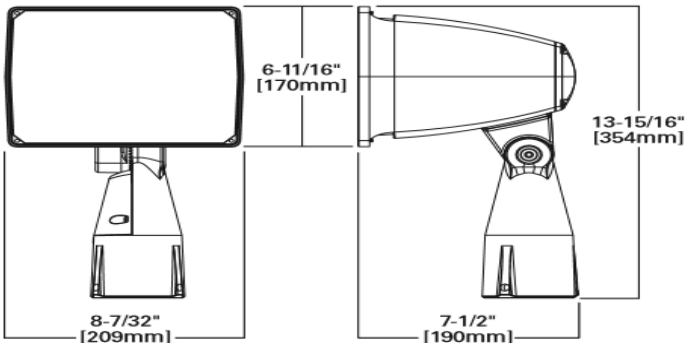

Knuckle Mount

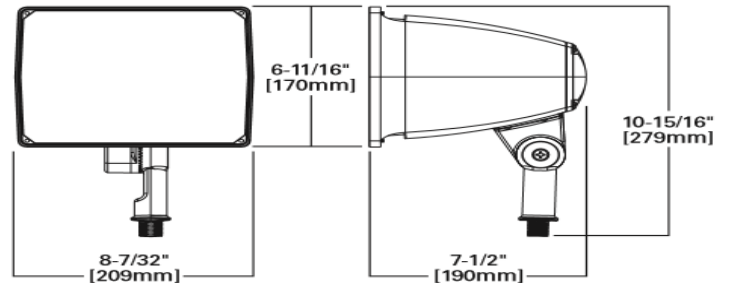

TRUNNION DRILLING PATTERN

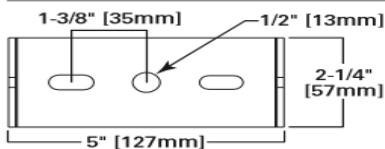

Trunnion Mount

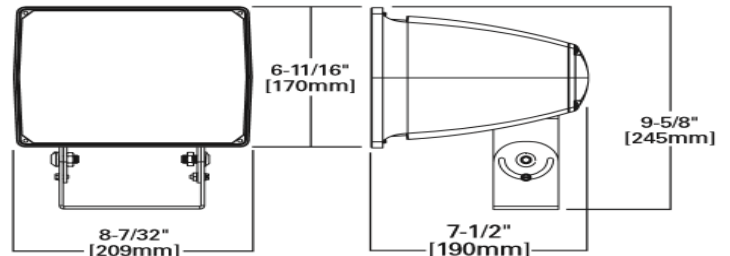

*www.designlights.org

STOCK ORDERING INFORMATION

Stock Sample Number: NFFLD-S-C15-T-UNV

Series	Light Engine	Mounting	Voltage	Options (Add as Suffix)
NFFLD-S=Night Falcon Small	C70=2,700 Nominal Lumens C15=5,900 Nominal Lumens	T=Trunnion KNC=Knuckle	UNV=Universal 120-277V 347=347V	PC1=Button Type Photocontrol - 120V PC2=Button Photocontrol - 207-277V

NOTES: Options not available with stock products. Order accessories as separate items for field installation. Refer to standard ordering information to add options. Refer to In-Stock Guide for availability. Stock fixture is 4000K, dimming, 6x6 distribution, 120-277V or 347V, carbon bronze only. 347V only available with PC2.

LUMARK: NFFLD NIGHT FALCON

The Night Falcon™ LED floodlight luminaire combines high-efficiency optics, superior thermal management and energy efficiency in a cost effective solution. The compact, robust design incorporates a separate driver compartment for maximum heat dissipation resulting in longer fixture and LED life. The Night Falcon luminaire uses precision engineered optics delivering superior uniformity and excellent illumination to the targeted application. Typical applications include area lighting for security, building facade lighting, accent and signage lighting in both commercial and industrial applications. The Night Falcon luminaire is UL/cUL listed for wet locations and is IP66 and 3G vibration rated.



DIMENSIONS

Silpfitter Mount

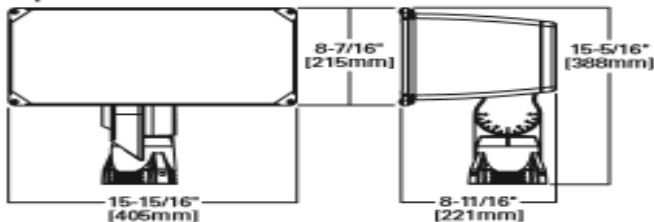

Trunnion Mount

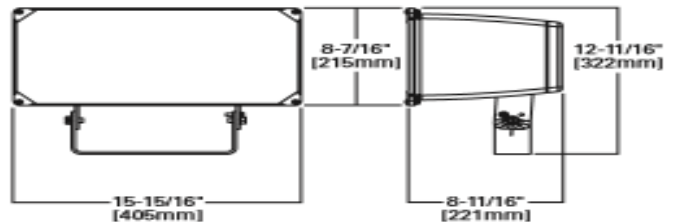

Yoke Mount

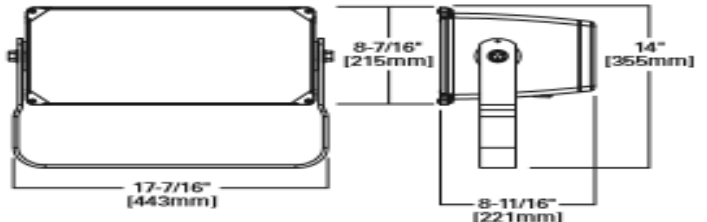

STOCK ORDERING INFORMATION

Stock Sample Number: NFFLD-C40-S

Series	Light Engine	Mounting	Voltage
NFFLD-Night Falcon	C25=10,500 Nominal Lumens C40=16,900 Nominal Lumens	S=Silpfitter T=Trunnion	[BLANK]=120-277V 347=347V

NOTES: Options not available with stock products. Order accessories as separate items for field installation. Refer to standard ordering information to add options. Refer to In-Stock Guide for availability. Stock fixture is 4000K, non-dimming, 120-277V or 347V 6Hz6V, carbon bronze only.

LUMARK: PRV PREVAIL LED

The Prevail™ LED area/site luminaire delivers a new level of performance, versatility and value in a low profile, patent pending, architectural design that delivers significant installation and energy savings. A versatile mount arm makes retrofit installation simple, resulting in reduced installation time and additional labor savings. With energy savings greater than 62%, the Prevail fixture replaces 150-400W metal halide fixtures in general area lighting applications such as parking lots, walkways, roadways and building areas. The Prevail luminaire is UL/cUL listed and is IP66 and 3G vibration rated to insure long term reliability.

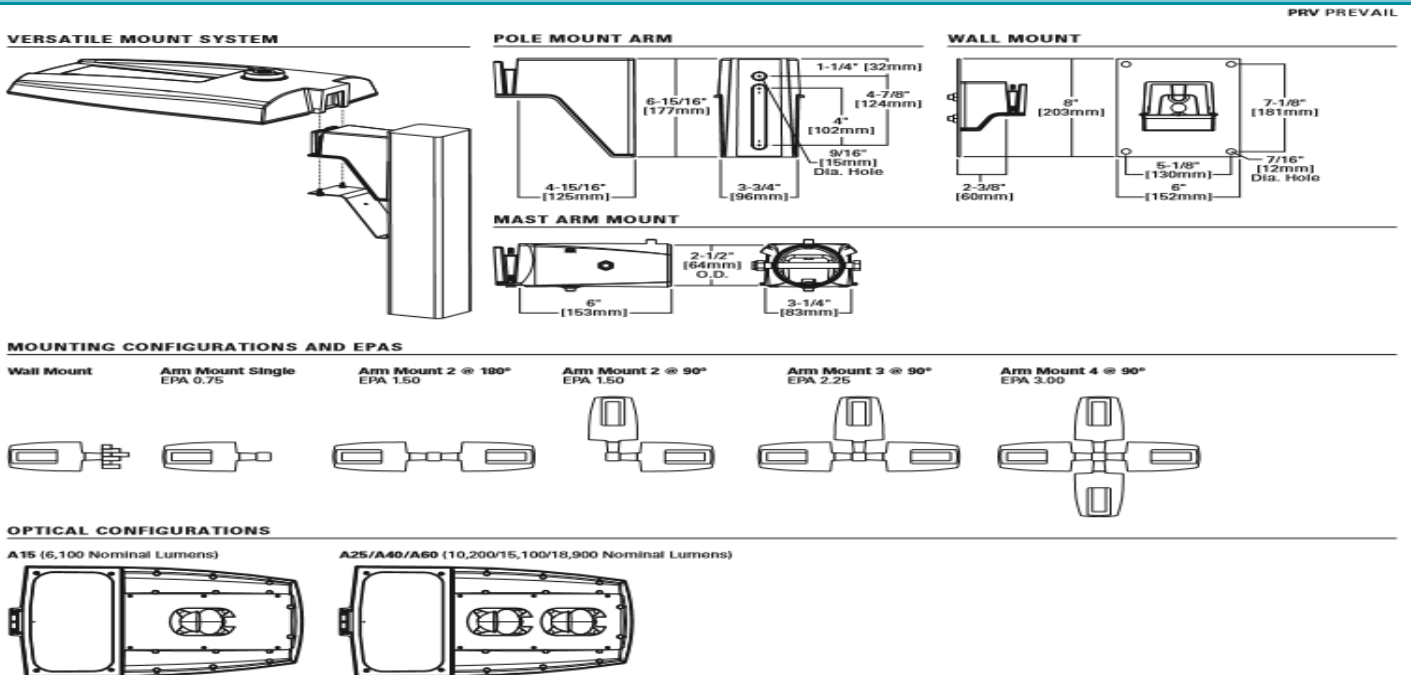

STOCK ORDERING INFORMATION

Stock Sample Number: PRVS-A25-UNV-T3

Product Family	Light Engine	Voltage	Distribution	Options (Add as Suffix)
PRVS=Prevail	A15-(1 LED) 6,100 Nominal Lumens A25-(2 LEDs) 10,200 Nominal Lumens A40-(2 LEDs) 15,100 Nominal Lumens A60-(2 LEDs) 18,900 Nominal Lumens	UNV=Universal (120-277V) 347-347V	T3=Type III T4=Type IV	MSP/DIM-L30=Integrated Sensor for Dimming Operation, Maximum 30' Mounting Height

NOTE: Bronze only, 4000K CCT, 120-277V, 347V, standard mounting arm, standard non-fused 10kV MOV and 0-10V dimming.

LUMARK: CLCSLED Canopy

The CLCSLED canopy luminaire provides a slim, low-profile, traditional design with high performance energy efficient illumination. Rugged die-cast aluminum construction and gasketed housing make the CLCSLED luminaire virtually impenetrable to contaminants. UL/cUL wet location listed. Replaces up to 400W metal halide equivalent. The CLCSLED canopy luminaire mounts quickly to a variety of surfaces making it ideal for bank and retail drive-thrus, covered side walks and hospitality entryways.



POWER AND LUMENS

4000K	CLCSLED-40	CLCSLED-55	CLCSLED-86	CLCSLED-117
Delivered Lumens	4,839	7,230	11,494	13,828
CCT (Kelvin)	4000	4000	4000	4000
CRI (Color Rendering Index)	70	70	70	70
Power Consumption (Watts)	36	56	92	121
5000K	CLCSLED-40	CLCSLED-55	CLCSLED-86	CLCSLED-117
Delivered Lumens	4,739	6,878	11,279	13,882
CCT (Kelvin)	5000	5000	5000	5000
CRI (Color Rendering Index)	70	70	70	70
Power Consumption (Watts)	36	56	90	120

CLCSLED

LUMEN MAINTENANCE

Ambient Temperature	TM-21 Lumen Maintenance (50,000 Hours)	Theoretical L70 (Hours)
25°C	94.88%	346,000

CURRENT DRAW

Voltage (V)	Model Series			
	CLCSLED-40	CLCSLED-55	CLCSLED-86	CLCSLED-117
	Current (A)	Current (A)	Current (A)	Current (A)
120V	0.31	0.47	0.73	0.45
208V	0.18	0.27	0.42	0.55
240V	0.15	0.23	0.36	0.47
277V	0.13	0.20	0.32	0.41

LUMEN MULTIPLIER

Ambient Temperature	Lumen Multiplier
10°C	1.03
15°C	1.02
25°C	1.00

ORDERING INFORMATION

Sample Number: CLCSLED-40-SM-UNV

Product Family ¹	Lamp Wattage	Mount	Voltage	Options (Add as Suffix) ²	Accessories (Order Separately)
CLCSLED	40=36W 55=56W 86=92W 117=121W	SM=Surface Mount	UNV=120-277V	Blank=70 CRI / 4000K 7050=70 CRI / 5000K BPC=120-277V Button Photocontrol 10KV=10kV Surge Protection	CLCSPEND=6" Long, 3/4" Pendant Mount

NOTES:
1. Available in bronze only.
2. Extended lead times apply.